

Leicestershire
County Council

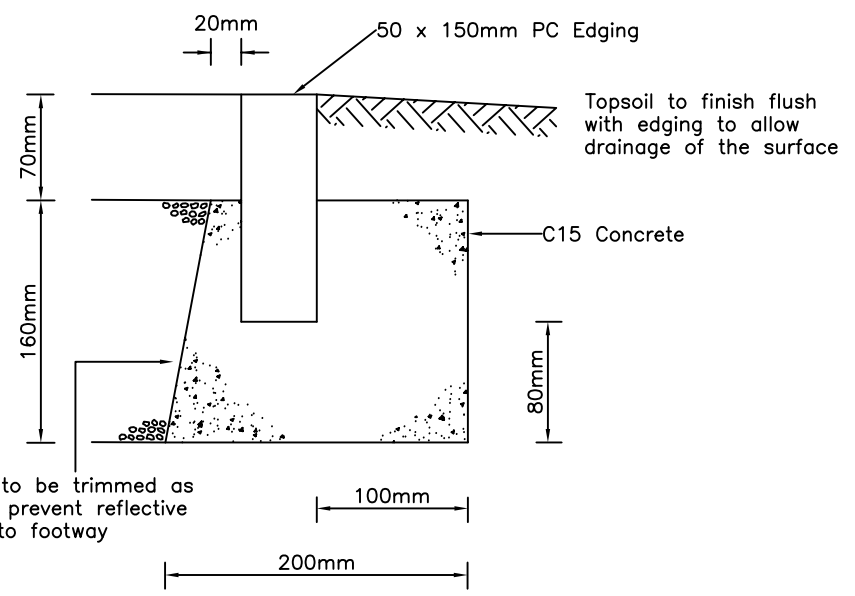
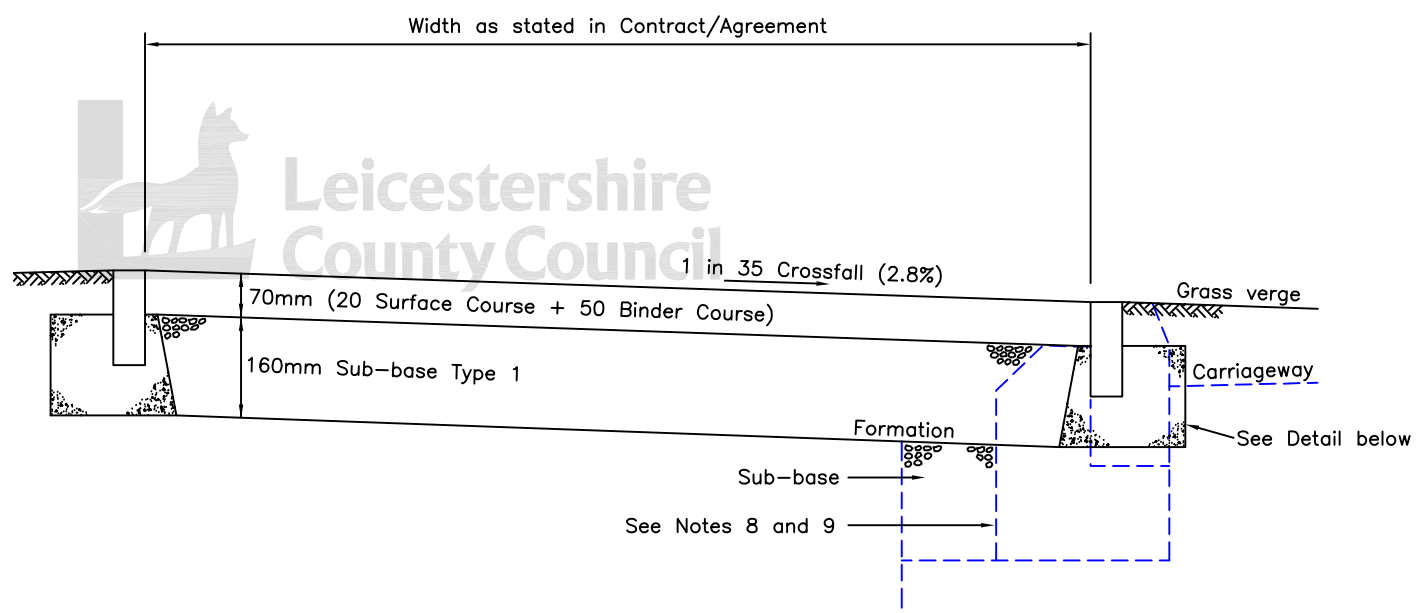

TOLERANCES ON NEW CONSTRUCTION

(Measured on a grid 5m Longitudinal 1m Transverse)

- Surface Course +6,-3
- Binder Course +6,-6
- Sub-base +10,-20
- Formation +10,-30

*Notwithstanding the tolerances permitted in surface levels of pavement courses, the cumulative tolerance shall not result in the reduction of the surfacing by more than 10mm at any point

NOTES:

1. Surfacing to be 6mm nominal size dense surface course (to BS EN 13108-1) 20mm thick and 20 nominal size dense binder course (to BS EN 13108-1) 50mm thick.
2. Surfacing on cycleways or CFC to be machine laid.
3. Crossfalls should be 1 in 35 or as directed by the Engineer.
4. Type 1 Sub-base to Clause 803.
5. 50 x 150mm precast concrete edgings Type EF to BS 7263.
6. (a) Where a footway, cycleway or CFC is crossed by a private vehicular access, the sub-base thickness should be increased to 225mm.
(b) Where a footway, cycleway or CFC is crossed by an agricultural field access, the sub-base thickness should be increased to 300mm.
7. The formation shall be trimmed, rolled and treated with a glyphosate based weedkiller in accordance with the Manufacturer's instructions prior to laying sub-base.
8. Where a footway/cycleway is adjacent to a carriageway the kerbing detail (shown dotted) should be incorporated as shown in detail on Drg No [SD/11/2].
9. On cycleways and CFCs adjacent to the carriageway, a safety margin strip is required. Permitted variants are shown on Drg No [SD/11/14].
10. Lamp columns, sign posts and other street furniture shall be sited 500mm outside the cycleway or CFC.

©Crown copyright 2012. All rights reserved. Use of this image is limited to viewing on-line and printing one copy. Leicestershire County Council, 100019271.