

- NOTES:
1. All dimensions are in millimetres unless otherwise stated.
 2. For kerb construction details see Drg No [SD/11/2].
 3. The 150 x 125 Half Batter kerb was formerly designated as a PC9 on BS 340.
 4. At the start of a cycleway or other locations where cyclists will be joining the cycleway at acute angles the number of flush kerbs should be increased to a minimum of four.
 5. Where specified, on new carriageways a 255 x 125 channel block to be laid over the width of the crossing. Foundation as per Drg No [SD/11/2].

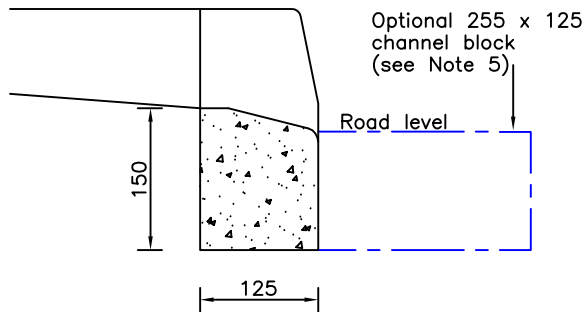

CROSS SECTION

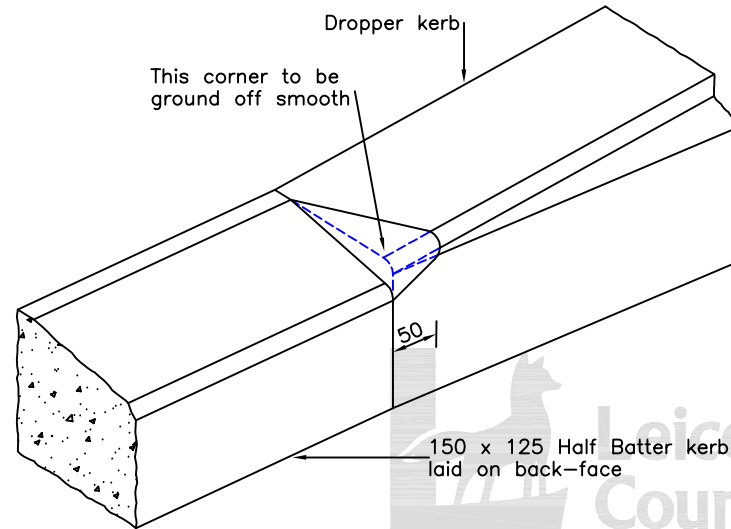

KERB DETAIL

©Crown copyright 2007. All rights reserved. Use of this image is limited to viewing on-line and printing one copy. Leicestershire County Council. 100619271.

DRAWING NUMBER	DATE			
SD/11/8	SEPTEMBER 2002			
AUTOCAD REF	SCALE			
K:\GENERAL\ID9997\STDDRG\SD118	NOT TO SCALE	Rev	Date	Notes on Revision